

SLUICE VALVE

Widely accepted by Municipal Corporations, Irrigation authorities, Water supply authorities, National Thermal Power Corporation, Nuclear Power Corporation and other Government and Industrial users, these valves are designed as per latest editions of IS specifications and they bear ISI mark (for Non Rising Spindle Sluice Valves).

Design Specifications

- Clear water having turbidity upto 5000 ppm and temperature upto 45° C
- Other fluids with maximum pressure / temperature conditions within the scope of IS:14846
- Valves can also be supplied upto 180° C working temperatures with special design, subject to working pressure limitations.

Salient constructional features

- Combination of excellent design features of reputed overseas valve brands
- Rigid and sturdy design with minimum loss of head across the valve
- Perfect interchangeability of components
- Assured parallelism between side flanges
- Assured equal taper between wedge faces
- Perfect machining and pressing of body and wedge rings
- Excellent finish on spindle threads resulting in low friction and smooth operation of valves
- Long service life and leak-tightness even after thousands of open / close cycles

Accessories (optional)

- Position Indicator
- By-pass arrangement (200 NB and above sizes)
- Repacking (Back Seat) arrangement
- Spur / Bevel / Worm gear arrangement (200 NB and above sizes)
- Thrust bearing arrangement (200 NB and above sizes)
- Channel and Shoe arrangement (Renewable) (300 NB and above sizes)
- Locking arrangement
- Extension shafting and head stock
- Electric actuator
- Drain plug
- Chain and Chain Wheel arrangement

Non Rising Spindle



Rising Spindle



Hydrostatic Test Pressures

Availability	Size Range	Manufacturing Standard and Pressure Rating	Hydrostatic Test Pressures in kg/cm	
			Body	Seat
Standard Supply	50 to 1200mm	IS:14846 PN 1.0	15	10
	50 to 600 mm	IS:14846 PN 1.6	24	16
Optional	700 to 1200mm	IS:14846 PN 1.6	24	16
		Dimensions as per PN 1.0, and tested to PN 1.6 pressures		
	1300mm	PN 0.6 Dimensionally as per KBL Standard	09	06
PN 1.0 Dimensionally as per KBL Standard		15	10	

Material of construction

	Body/Wedge/Dome	Body/Wedge/Rings	Spindle	Stem Nut
Standard Supply	Cast Iron	Leaded Tin Bronze as per IS:318 Gr LTB-2	St. Steel as per IS:6603 Gr.12Cr12	Leaded Tin Bronze as per IS:318 Gr LTB-2
Optional	SG. Iron as per IS:1865, 2% NiCl, ASTM A 439 Type D2 Cast Steel as per IS:1030/ASTM A 216 Gr WCB	St. Steel as per IS:1570; IS:6603 ASTM A 276; BS:970 standards	High Tensile Brass; St. Steel as per IS:1570; IS:6603; ASTM A BS:970 standards	High Tensile Brass

Note: For special material of constructions, please contact us.
We also supply valves with Corrocoat coating for sea water application.

End connections

Availability	Flange Drilling Standard
Standard Supply	IS:1538 Table 4 and 6
Optional	BS 10, Table D/E /F BS EN 1092.2 (BS:4504) 6, 10 and 16 Bar IS:1538 Table 5 ANSI B 16.1/B 16.5, DIN 2532 (10 Bar), IS: 6392



Non Rising Spindle Sluice Valves

VALVE SIZE	F	M	H APPROX.	H1
50	178	143	350	410
65	190	214	365	425
80	203	218	405	460
100	229	244	460	550
125	254	280	515	575
150	267	312	555	630
200	292	444	720	775
250	330	482	810	875
300	356	574	910	1010

With preferred face to face dimension

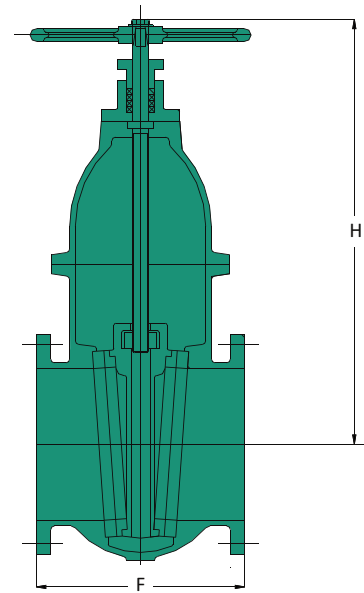

RATING	VALVE SIZE	F	M	H APPROX.	H1
PN 1.0 & PN 1.6	350	381	640	950	1050
	400	406	680	1005	1105
	450	432	770	1167	1267
	500	457	860	1237	1337

With preferred face to face dimension

RATING	VALVE SIZE	F	M	H APPROX.	H1
PN 1.0	350	550	634	950	1050
	400	600	675	1005	1105
	450	650	720	1167	1267
	500	700	870	1237	1337
	600	800	984	1379	1479
PN 1.6	350	550	692	950	1050
	400	600	780	1108	1208
	450	650	800	1200	1300
	500	700	890	1355	1455
	600	800	979	1429	1529

With 'alternate 1' face to face dimension

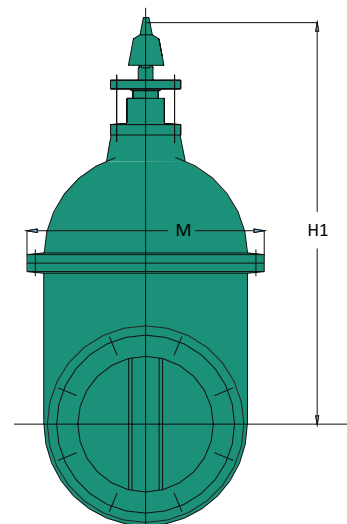

Non Rising Spindle Sluice Valves

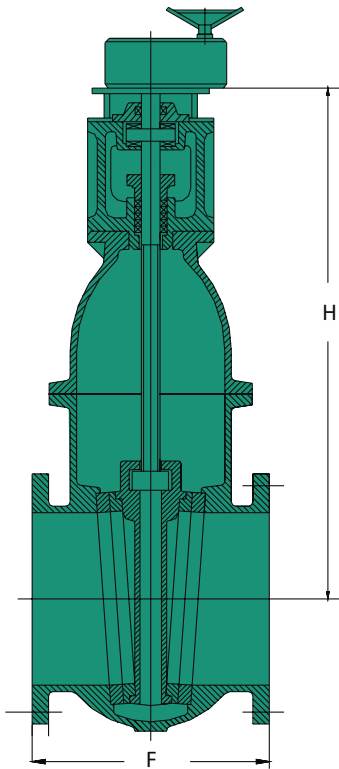

VALVE SIZE	F	M	H APPROX.
700	610	1910	1100
750	610	2025	1170
800	660	2050	1220
900	711	2240	1330
1000	811	2400	1450
1200	810	2600	1670
1300	1016	3100	1925

With preferred face to face dimension

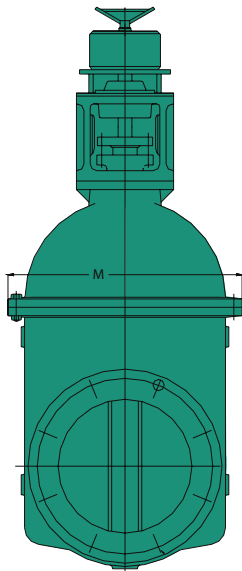

700	900	1910	1100
750	950	2025	1170
900	1100	2240	1330
1100	1300	2650	1550
1200	1400	2950	1738

With 'alternate 1' face to face dimension



Rising Spindle Gate Valves

VALVE SIZE	F	M	H OPEN	J SHUT
50	178	143	350	410
65	190	214	365	425
80	203	218	405	460
100	229	244	460	550
125	254	280	515	575
150	267	312	555	630
200	292	444	720	775
250	330	482	810	875

With preferred face to face dimension

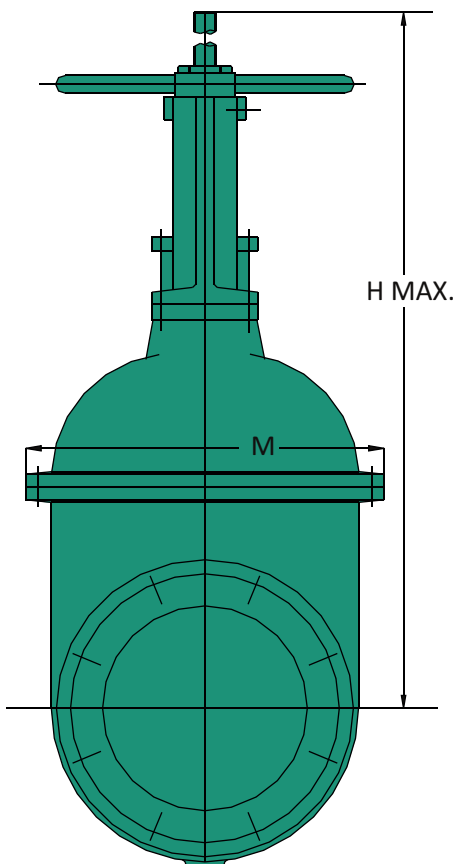
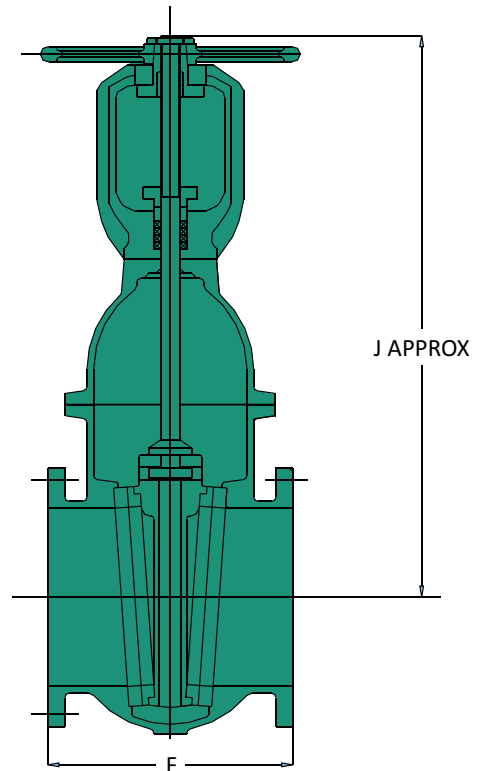

Rising Spindle Gate Valves

RATING	VALVE SIZE	F	M	H APPROX.	H1
PN 1.0 & PN 1.6	350	381	640	1750	1320
	400	406	680	1860	1450
	450	432	770	2120	1600
	500	457	860	2285	1715
	600	508	940	2625	1955

With preferred face to face dimension

PN 1.0	350	550	634	1750	1320
	400	600	675	1860	1450
	450	650	720	2120	1600
	500	700	870	2285	1715
	600	800	984	2625	1955

PN 1.6	350	550	692	1750	1320
	400	600	780	1960	1485
	450	650	800	2150	1625
	500	700	890	2490	1865

